

BATTERY APPROVAL SHEET

电池规格承认书

CUSTOMER NAME
(客户名称)

BATTERY MODEL 402025-150mAh
(电池型号)

SPECIFICATION NO. UF-402025
(规格书编号)

TOTAL NO. OF PAGES 10 pages
(页数)

DATE 2013-4-8
(日期)

REMARKS single/ (单体)
(备注)

Manufacturer	Prepare/date	Check/date	Approval/date
Customer Approval	Check/date		Approval/date

UNIONFORTUNE

SHIDA BATTERY TECHNOLOGY CO., LTD

AMENDMENT RECORDS**(变更记录)**

Revision	Description	Date	Approval
A.0	New release	2013-4-8	

Content (目录)

1. Scope.....	4
2. Description and Model.....	4
3. Nominal Specifications.....	4
4. Outline Dimensions	5
5. Appearance.....	5
6. Standard Test Conditions.....	5
7. Characteristics.....	6
8. Mechanical Characteristics.....	7
9. Safety.....	7
10. Warranty.....	7
11. Others.....	8

Appendix (附录)

1. General.....	9
2. Charging.....	9
3. Discharging.....	9
4. Storage.....	10
5. Other.....	10

1. Scope

This product specification has been prepared to specify the rechargeable Lithium-ion Polymer battery to be supplied to the customer by Unionfortune..

适用范围

本规格说明书描述了 Unionfortune 生产的可充电聚合物锂离子电池芯的产品性能指标

2. Description and Model

型号描述

2.1 Description: Lithium Ion Polymer battery

描述: 聚合物锂离子电池

2.2 Model: 402025-150mAh

型号: 402025-150mAh

3. Nominal Specifications

产品规格

Item	Specification	Remark
3.1 Nominal Capacity 标称容量	150mAh	0.2C discharge
3.2 Minimum. Capacity 最小容量	147mAh	0.2C discharge
3.3 Nominal Voltage 标称电压	3.7V	
3.4 Charge Voltage 充电电压	4.20±0.02V	
3.5 Charge Current 充电电流	Standard charge(标准充电) :0.5C (75mA) Rapid charge(快速充电) : 1.0C (150mA)	0~40°C
3.6 Charging Time 充电时间	Standard charge(标准充电) : 3.0 hours (Ref.) Rapid charge(快速充电) : 2.0 hours (Ref.)	
3.7 Max. charge current 最大充电电流	1.0C (150mA)	
3.8 Cont.. Discharge Current 持续放电电流	1.0C (150mA)	0~40°C
3.9 Burst Discharge Current 瞬间放电电流	2.0C (300mA)	0~40°C
3.10 Cutoff Voltage 截止电压	2.75V	
3.11 Resistance 内阻	≤320mΩ	1kHz AC Method
3.12 Weight (Approx.) 重量(约)	4.0g	
3.13 Dimensions(T.W.H.) 尺寸	Thickness(厚度): 4.2mm MAX Width(宽度): 21.0mm MAX Length(长度): 27.0mm MAX	
3.14 Operating Temperature 工作温度	Charge(充电) : 0 ~ 40°C Discharge(放电) : -20 ~ 60°C	
3.15 Storage Temperature 储存温度	1 year : -20~20°C 3 months : -20~25°C	

Note:

Standard Charging method 0.5C(75mA) CC (constant current) charge to 4.2V, then CV(constant voltage 4.2V) charge till charge current decline to $\leq 0.05C$ (8mA) .

标准充电方式是用0.5C(75mA) CC (恒流) 充电至 4.2V,再 CV (恒压4.2V) 充电直至充电电流 $\leq 0.05C$ (8mA).

4. Outline Dimensions

尺寸简图

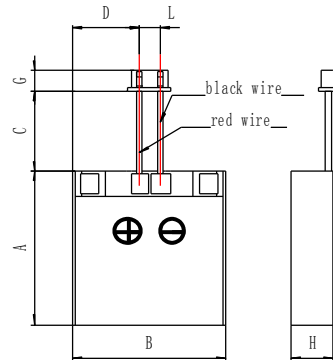

Item	Description	Dimension and specification
H	Thickness	4.2mm max
B	Width	21.0mm max
A	Length	27.0mm max
C	24AWG, Red/black wire length	100mm
	Connector	JST PHR-2

5. Appearance

外观

There shall be no such defects as scratch, discoloration, leakage which may adversely affect commercial value of the cell.

电池表面无划痕、脏污、电解液泄漏等影响电池价值的外观缺失。

6. Standard Test Conditions

标准测试条件

6.1 Environmental Conditions

Unless otherwise specified, all tests stated in this specification are conducted at temperature $25\pm 5^{\circ}\text{C}$ and humidity $60\pm 20\%$.

环境要求

除非特殊说明，否则所有测试都在温度 $25\pm 5^{\circ}\text{C}$ 湿度 $60\pm 20\%$ 的环境中测试

6.2 Measuring Equipment

测量设备

(1) Ammeter and Voltmeter

Standard class specified in the national standard or more sensitive class

电压表和电流表

国家标准或更灵敏等级

(2) Slide caliper

The slide caliper should have 0.02 mm scale.

游标卡尺

游标卡尺的精度在0.02mm以上

(3) Impedance meter

The impedance meter with AC 1kHz should be used.

内阻仪

内阻仪测量方法为交流阻抗法

7. Characteristics

性能

7.1 Standard Discharge Capacity

The standard discharge capacity is the initial discharge capacity of the cell, which is measured with discharge current of 30mA with 2.75V cut-off at $25\pm 5^{\circ}\text{C}$ within 1 hour after the standard charge.

Standard Discharge Capacity $\geq 147\text{mAh}$

标准放电容量

标准放电容量是指电池最初的放电容量;将采用标准充电方法充电后的电池用30mA进行放电,放电终止电压2.75V,环境温度 $25\pm 5^{\circ}\text{C}$ 电池应在充电完成1小时内进行测试。

标准放电容量 $\geq 147\text{mAh}$

7.2 Cycle Life

Each cycle is an interval between the charge at CC-CV (75mA-4.2V) for 3h and the discharge (discharge current 75mA) with 2.75V cut-off. After 300 cycles, measure capacity under the same condition in 7.1.

Capacity $\geq 120\text{mAh}$ (80% of the capacity at 25°C)

循环寿命

电池采用恒流恒压方法充电至4.2V,充电电流 75mA,充电时间约3小时;然后采用 75mA将电池恒流放电至2.75V,每次充放电中间需要有一定的时间间隔,经过300个循环后,采用7.1方法对电池进行容量测试。

容量 $\geq 120\text{mAh}$ (初始容量的80%)

7.3 Initial internal impedance

Initial internal impedance measured at AC 1kHz after 50% charge.

Initial internal impedance $\leq 320\text{m}\Omega$

初始内阻

半充状态下, 测量其AC 1KHz下的交流阻抗

初始内阻 $\leq 320\text{m}\Omega$

7.4 Storage Characteristics

Capacity after storage for 28 days at 25°C from the standard charge, measured with discharge current 30mA with 2.75V cut-off at 25°C

Capacity retention (after the storage) $\geq 128\text{mAh}$ (85% of the capacity at 25°C)

储存性能

电池采用标准充电方式充满电后 25°C 储存28天,然后30mA放电至2.75V.

剩余容量(储存后) $\geq 128\text{mAh}$ (初始容量的85%)

7.5 Status of the cell as of ex-factory

The cell should be shipped in 50% charged state. In this case, OCV is not less than 3.85V.

电池出厂状态

电池出厂携带50%以上的电量,测试开路电压应在3.85V以上.

8. Mechanical Characteristics

机械性能

8.1 Drop Test

Test method: Cell (as of shipment or full charged) drop onto concrete ground from 1.0m height at a random direction 6 times.

Criteria: No fire, and no explosion.

跌落测试

测试方法: 电池(出货条件或充满电情况下)从1米高度沿任意方向跌落到混凝土上6次.

标准: 无起火、爆炸

8.2 Vibration Test

Test method: After standard charging, fixed the cell to vibration table and subjected to vibration cycling that the frequency is to be varied at the rate of 1Hz per minute between 10Hz and 55Hz, the excursion of the vibration is 1.8mm. The cell shall be vibrated for 30 minutes per axis of XYZ axes.

Criteria: No fire, and no explosion.

振动测试

测试方法: 将标准充电后的电池固定在振动台上, 沿X、Y、Z三个方向各振动30分钟, 振幅1.8mm, 振动频率10Hz~55Hz, 每分钟变化1Hz.

标准: 无起火、爆炸

9. Safety

安全性

9.1 Overcharge Test

Test method: To charge the standard charged cell with 150mA constant current until cell voltage reaches 4.6V, then be charged at constant voltage of 4.6V while tapering the charge current at 25°C for 2.5hrs.

Criteria: No fire, and no explosion.

过充测试

测试方法: 标准充电后, 150mA恒流恒压将电池充电至4.6V, 时间限制2.5小时。

标准: 无起火、爆炸

9.2 External Short-circuit Test

Test method: To short-circuit the standard charged cell by connecting positive and negative terminal by less than 50mΩ wire.

Criteria: No fire, and no explosion.

外短路测试

测试方法: 电池标准充电后,使用内阻小于50mΩ的导线将电池正负极连接

标准: 无起火、爆炸

10. Warranty

Unionfortune will be responsible for replacing the battery against defects or poor workmanship for 12 months from the date of shipping. Any other problem caused by malfunction of the equipment or mix-use of the battery is not under this warranty.

品质担保

因制作问题而导致的不良品Unionfortune负责给予换货，电池出厂期限应在12个月内；因为设备故障或滥用而导致的不良品不在此列。

11. Others

其他内容

11.1 Storage for a long time

If the cell is kept for a long time(3months or more), It is strongly recommended that the cell is preserved at temperature range(0-25°C),low humidity, no corrosive gas atmosphere.

长时间储存

3个月或更长时间储存的电池，建议在0-25°C、低湿度、无腐蚀性气体的环境中放置。

11.2 Other

Any matters that this specification does not cover should be conferred between the customer and UF.

未尽事宜由供需双方协商而定。

Appendix 附页

Proper Use and Handling of Lithium Ion Polymer (LIP) battery
聚合物锂离子电池使用说明及注意事项

1. General

This document has been prepared to describe the appropriate cautions and prohibitions, which the customer should take or employ when the customer uses and handles the Lithium Ion Polymer (LIP) battery to be manufactured and supplied by Unionfortune, in order to obtain optimum performance and safety.

前言:

本内容为 Unionfortune 生产的聚合物锂离子电池在使用过程中的一些指导和警告, 请消费者仔细阅读并遵守, 以便于获得最佳的使用性能和最可靠的安全性。

2、Charging

充电

2.1 Charge current: Charge current should not more than the maximum charge current specified in the Product Specification (normally 0.5C-1.0C or lower). Charging with higher current may damage the cell or even lead to safety problem, e.g. overheating or leakage.

充电电流: 充电电流不得超过规格书规定的最大充电电流(一般情况下为 0.5C~1.0C 或以下), 使用高于推荐值电流充电将可能引起电池的充放电性能、机械性能和安全性能的问题, 并可能导致发热或泄漏。

2.2 Charge voltage: Charge voltage shall not more than that specified in the Product Specification (4.2V/cell). 4.25V is the maximum charging voltage for each cell. Never charge the battery in series and be sure that each single cell has a separated charging circuit with a max. Charging voltage of 4.25V or the battery may be overcharged, and lead to fire or explosion. The user is fully responsible to the result of misusing the battery.

充电电压: 充电电压不得超过规定的限制电压(4.2V/单体电池)4.25V 为每只电池充电电压的最高极限。对串联电池组, 必须采用平衡充电或者每只电池单独充电的方法, 任何时候必须保证加在单只电池两端的电压不能超过 4.25V (严禁采用串联充电, 否则可能对电池过充电而使电池漏液、起火甚至爆炸; 用户由于错误使用电池产生的后果自负)。

2.3 Charge temperature: The cell should be charged within the range of temperatures specified in the product Specification. Stop charging immediately when the surface temperature of the battery is over 50°C.

充电温度: 电池必须在产品规格书规定的环境温度范围内进行充电, 否则电池易受损坏。当发现电池表面温度异常时(指电池表面温度超过 50°C), 应立即停止充电。

2.4 Reverse charging: Please make sure the polarities of cells are connected properly before charging is strictly prohibited. Reverse charging cannot charge the cells but will deteriorate their charging/discharging and safety characteristics, or even lead to fire or explosion.

反向充电: 正确连接电池的正负极, 严禁反向充电。若正负极接反, 将无法对电池进行充电。反向充电会使用电池受到致命的破坏, 甚至导致发热、泄漏、起火、爆炸。

3、Discharging

放电

3.1 Discharge current: The cell shall be discharged at the current no more than the maximum discharging current specified in the Product Specification. Over current discharging may damage the battery and cause over-heat.

放电电流: 放电电流不得超过规格书(承认书)规定的最大放电电流, 过大电流放电会导致容量剧减并导致电池过热膨胀。

3.2 Operation temperature: Use the battery within the temperature range specified in the Product Specification. Stop using when temperature is over 70°C

放电温度：电池必须在规格书规定的工作温度范围内放电。当电池表面温度超过 70°C 时，要暂停使用，直到电池冷却到室温为止。

3.3 Over-discharge: Over-discharge will deteriorate the cell's performance and characteristics. Do not over-discharge a battery below 2.75V/cell.

过放电：过放电会导致电池损坏，放电时不得使单体电池的电压低于 2.75V。

4、Storage

If you intend to keep the battery for a long time (3months or longer), it is strongly recommended that the battery shall be stored under the environment with temperature 10-25°C low humidity and without corrosive gas. The battery should be charged every six months to ensure that each cell's storage voltage is 3.6~3.9V.

贮存

电池应放置在阴凉干燥的环境下贮存，长期存放电池时（超过 3 个月），建议置于温度为 10-25°C 且低湿度无腐蚀性气体的环境中。电池在长期贮存过程中每六个月应充电一次，以保证每个电芯电压在 3.6~3.9V 范围内。

5、Others

其他注意事项

The aluminum packing foil is very soft that it will be easily left scratches. Please do not hit the battery with any sharp edge parts.

由于电池采用软包装，其铝箔包装材料很容易被划伤，因此禁止使用尖锐物品碰撞电池。

Don't fall, hit or bend the battery. It may cause fire or explosion.

禁止坠落、冲击、弯折电芯，以免引起火灾。

Short circuit the battery is strictly prohibited; it may damage the battery seriously.

禁止将电池正负极直接短路，否则可能导致电池严重损坏，甚至引起火灾。

Never disassemble the battery. It may cause fire.

在任何情况下不得拆卸电池，否则会导致内部短路，进而引起鼓气、着火。

Never dispose of the battery in fire. It is very dangerous and strictly prohibited.

严禁将电池投入火中，以免产生危险。

To immerge the battery into liquid such as water is strictly prohibited.

严禁将电池浸入液体中，如水等。

Avoid vibration, shock or extrude the battery. Handle carefully when moving it.

在运输过程中防止剧烈振动、冲击或挤压，在搬运时应轻拿轻放，且电池必须使用柔软包装物做好防护。